

Finder of this certificate has no right to retain it.

He should either deposit it with the nearest Police Station or post it to the Issuing Authority

IAFY – 1964 (Rev)

COMBINED CERTIFICATE OF DISCHARGE & RECOMMENDATION FOR CIVIL EMPLOYMENT

(Issued under the Provisions of AA Sec 22 & 23 to be read with AR 12 and RA Para 168)

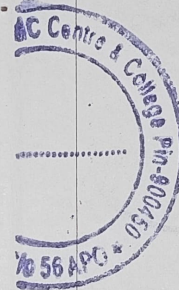

EX-SERVICEMEN
(GREEN BOOKLET)

Army No : JC702408K

Rank : SUB

Trade : SKT

Name : PARGE YUVARAJ SOPAN

Regt : Army Medical Corps

INSTRUCTIONS

1. This is a non transferable document and will be issued duly serially numbered.

2. It will be issued to a soldier only once, ie at the time of his discharge from the first enrolment. In the case of an ex-serviceman securing re-enrolment in the Army, the Discharge Certificate in his possession will be withdrawn from him and kept along with his service documents. When he is discharged from the subsequent enrolment, the discharge certificate withdrawn from him will be re-issued to him with the portion relating to re-enrolment, duly completed.

3. Any amendment/alteration/correction/attempt to tamper the entries will render the document invalid. The same will be considered as an offence. The personnel responsible for the same is liable for prosecution.

4. Amendments in the document, if any should be attested under the seal of the issuing authority.

5. In case of loss of this document, the Officer-in-Charge Records may, if satisfied as to the cause of its loss, issue IAFY 1964A in lieu. Duplicate Discharge Certificate will never be issued in case the ex-serviceman is already in possession of the original one.

6. Loss of this certificate is to be reported to the nearest Police Station and copy of FIR obtained. Application for issue of Duplicate Discharge Certificate should be submitted to Record Office concerned, on occurrence, duly supported by a copy of FIR, through the concerned Zila Sainik Board.

10. Contact details of DIAV & your Record Office are as under :-

(a) DIAV

(i) Family Pension Helpline
011-25664100 (Landline)
9910964067 (Mobile)
Email : diav.pne@gov.in

(ii) Service Pensioners Helpline
011-25664200 (Landline)
9910610866 (Mobile)
Email : diav.vsk@gov.in

(b) Record Office

(i) Helpline No : 0522-2483324 (Landline)
09116249299 (Mobile)

(ii) E-mail ID : comb.heat@nic.in

NOTES

1. The term family includes wife / husband, mother, father and unmarried children including step / adopted children upto 25 years of age who are dependent on the pensioner. Unmarried daughter/married divorced daughter and handicapped children are eligible for life subject to fulfilling other conditions.

2. Non-pensioners are not entitled medical attendance/ treatment from service sources.

3. Birth, Death, Divorce, Marriage, Adoption or any other occurrence will be published by Record Office after retirement on reporting by the Ex-serviceman through Zila Sainik Board.

Army / JC No : JC702408K

20

GENERAL INSTRUCTIONS

1. The Service and Discharge Certificate will only be issued on release from the Army as per Army Act Sec 22 & 23 to be read in conjunction with Army Rule 12 and Para 168 of Regulations for the Army 1987.
2. Ensure that your NOK is nominated for your Pension Account.
3. If you want assistance in obtaining employment on leaving service, visit to the nearest Employment Exchange and get your name registered with them and also with APN/AWPO. You will be issued with a Registration Card by the Employment Exchange. Please ensure timely renewal of your Registration from time to time, as directed by the Employment Exchange.
4. If you experience any difficulty in getting the Registration Card renewed, you should contact the Secretary of the RSB/ZSB or the Recruiting Officer of your area who will arrange for the renewal of your Registration Card.
5. If you want immediate employment, apply at once. If the kind of job you want is not immediately available, your name will be noted.
6. You may also approach the Ministry of Defence, Directorate General of Resettlement, New Delhi for availing of various re-employment schemes.
7. In order to ensure uninterrupted remittance of pension, please ensure timely submission of your Annual Life Certificate.
8. Please log in to your SPARSH account regularly and raise grievance, if any, with regards to remittance of pension etc on the same.
9. You may approach Officer-in-Charge Records for any of your grievance / query, post retirement.

Army / JC No : JC702408K

1

Disch Book Ser No : 664/2024



(आज (NOK)
(Khan)
लो कर्नल
Lt Col
डिपो कम्पनी कमान्डर
Depot Coy Cdr
कृते कमान अधिकारी

PERSONAL / SERVICE PARTICULARS

- | | |
|------------------------------------|-----------------------|
| 1. Army No | : JC702408K |
| 2. Rank | : SUB |
| 3. Trade | : SKT |
| 4. Name in Full
(Block Capital) | : PARGE YUVARAJ SOPAN |
| 5. Father's Name
(In full) | : SOPAN MAHADEV PARGE |
| 6. Religion | : Hindu |
| 7. Caste | : MARATHA |
| 8. Whether SC/ST | : N/A |
| 9. Date of Birth | : 01 Aug 1974 |

10. Date of Enrolment : 30 Jun 1994
11. Date of Discharge : 30 Jun 2024
/Invalidment
12. Cause of Discharge : On completion of service or
tenure or on reaching age
limit
13. Clause of Discharge : AR 13(3)I(i)(a)
14. Total Qualifying Service : 30 Years 0 Months 1 Days
(Total Embodied Service in Case of TA)
15. Character : Exemplary
16. Colour of Eyes : Black
17. Height : 168 cms
18. Visible Identification :
Marks
(a) MOLE 7 CM AT 10 `O` CLOCK RT NIPPLE
(b) MOLE INFRONT 7 CM LT SHOULDER

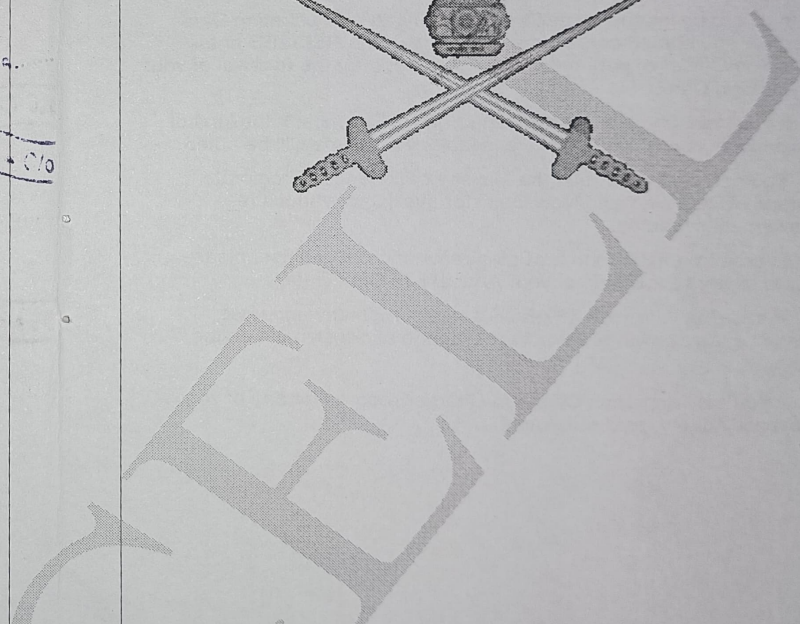
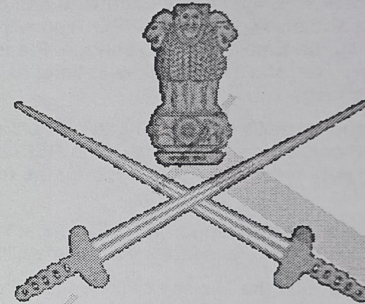
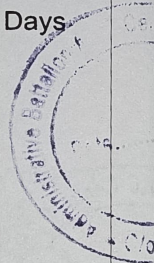

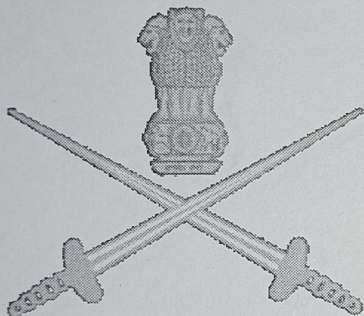

19. Marital Status : Married
 20. Name and Relationship with NOK : PRITI YUVRAJ PARGE (Spouse)
 PAN No : BJIPP7639E
 Aadhar No : 709675253931
 Mobile No
 E Mail ID
 Permanent Home Address :-
 House No/Name of Street/Road/Mohalla : FLAT NO. 2, KALPTARU APPARTMENT .
 Village Town :
 Post Office : NDA ROAD WARJE MALWADI
 Tehsil :
 Nearest Railway Station : PUNE
 District : PUNE
 State : MAHARASHTRA
 PIN : 411058
 Dependent Rajya Sainik Board : MAHARASHTRA
 Dependent Zila Sainik Board : PUNE

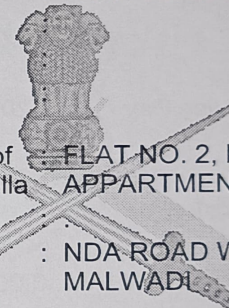
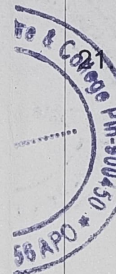

22. Aadhar No : 347615338862
23. E Mail ID : yuvrajparge74@gmail.com
24. PAN : ANTPP0301M
25. Mob No : 9621188410
26. Last Pay Drawn
- | | |
|----------------------|---------|
| Basic Pay | : 55200 |
| X Group Pay | : 0 |
| Military Service Pay | : 5200 |
| Class Pay | : 0 |
| Total | : 60400 |
27. Service Pension
- (a) PPO No :
- (b) Amount : 0.00
28. Disability Pension
- (a) PPO No :
- (b) Amount : 0.00
29. AWPO Registration No :
(If Registered)
30. DIAV Registration No :

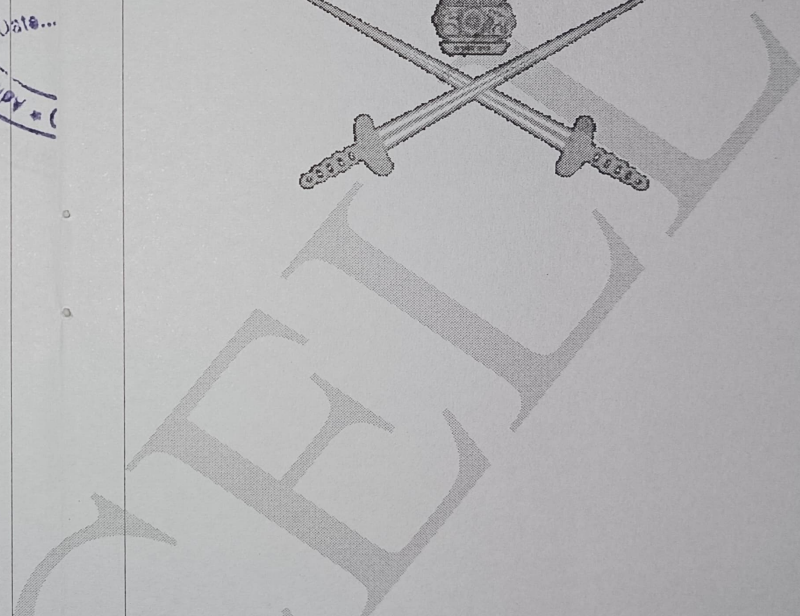
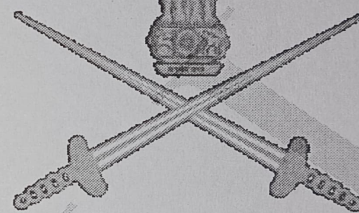
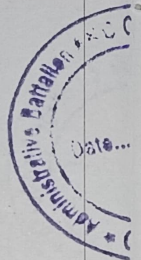
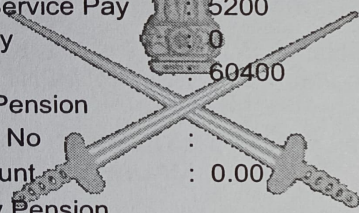

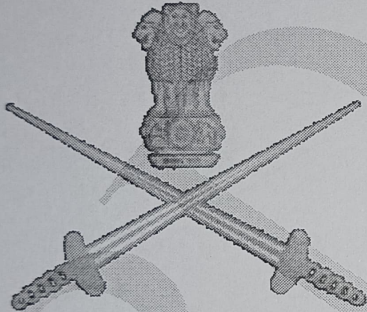

31. Details of Family (Including Handicapped Children, if any) :-

Ser No	Name	Relationship Gender	DOB Part II Order No
(a)	PRITI YUVRAJ PARGE	Spouse Female	<u>01/05/1982</u> 0/0032/0012/2000
(b)	MEGHANA YUVRAJ PARGE	Daughter Female	<u>27/01/2002</u> 0/0049/0001/2005
	MITALI YUVARAJ PARGE	Daughter Female	<u>11/10/2003</u> 0/0071/0010/2010
(d)	AMAR YUVRAJ PARGE	Son Male	<u>28/11/2004</u> 0/0049/0002/2005
(e)	SOPAN MAHADEV PARGE	Father Male	<u>01/08/1949</u> 0/0179/0074/1994
(f)*	VIMAL SOPAN PARGE	Mother Female	<u>21/07/1954</u> 0/0179/0074/1994
(g)	RAM SOPAN PARGE	Brother Male	<u>11/09/1976</u> 0/0179/0074/1994
(h)	MUKTTA SOPAN PARGE	Sister Female	<u>01/07/1978</u> 0/0179/0074/1994

32. Details of Service Rendered in Field / HAA (Including Counter Insurgency Operations):-

Ser No	Details of Area	From To	Type of Operation
(a)	CMFAA	10/03/1999 12/08/2002	OP RAKSHAK
(b)	SCCIA (FIELD)	28/11/2012 01/10/2015	OP RAKSHAK

(Note : Complete tenure in a particular qualifying area/theatre be taken from the date of TOS to SOS)

33. Details of Service Rendered in Missions Abroad:-

Ser No	Name of Mission	From	To
(a)	()		

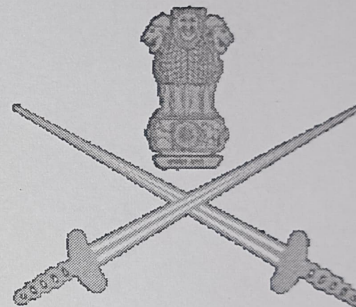
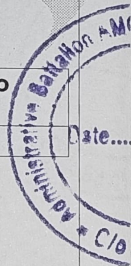

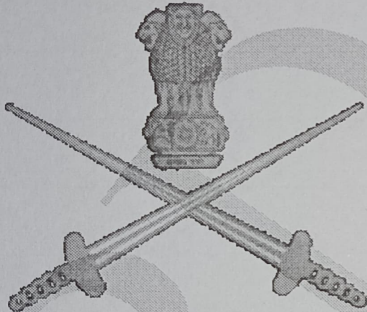

34. Details of Instructional and Deputation Service:-

Ser No	Unit	From	To
--------	------	------	----

35. Details of Medals / Decorations / Honours & Awards :-

Ser No	Name of Medal / Decoration / Award	Date of Award	Part II Order No
(a)	Sainya Seva Medal W/C J&K	28/11/2012	0/0011/0026/2015
	Special Service Medal W/C SURAKSHA (Op Rakshak)	28/11/2012	0/0011/0027/2015

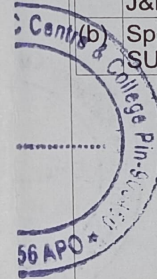

36. Highest Academic/Technical Qualification:-

Ser No	Qualification	Year of Passing	University / Board
(a)	Matriculation	1990	

37. Details of Courses including Army, Information Technology Courses / Cadres/Up-classification and Proficiency in Driving:-

Ser No	Details of Course / Cadres (s)	Grading	Duration From To
(a)	NB SUB CADRE		10/02/2015
(b)	Upclass - 1		16/12/2001

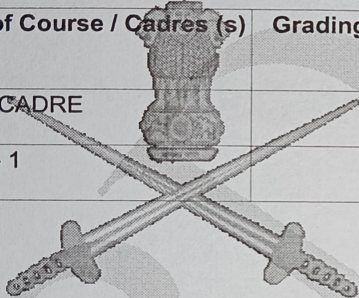
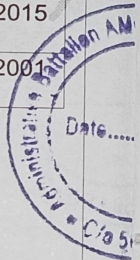

PART IV

TO BE FILLED IN BY DEPENDENT CSD CANTEEN

1. Details of CSD Card :-

Ser No	Name of Beneficiary	Relationship	Date of Birth	Card No	Type of Card

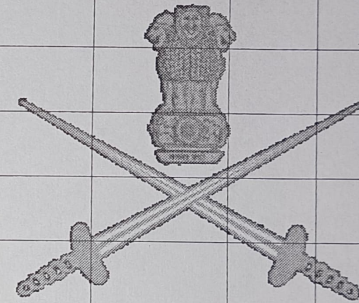

Station :-

Date :-

(Signature with Seal)

PART III

TO BE FILLED IN BY ECHS POLYCLINIC / STATION HEADQUARTERS

1. Details of ECHS Card :-

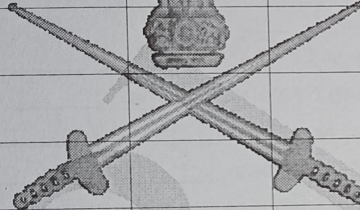
Ser No	Name of Beneficiary	Relationship	Date of Birth	ECHS Card No
				
				

Station :

Date :

(Signature with Seal)

38. Details of Resettlement / Vocational Courses :-

Ser No	Details of Course	Result	Duration	
			From	To
(a)				

39. Medical Category Details:-

Medical Cat	Disabilities / Diagnosis	Percentage	Whether BC or PC	Attributability / Aggravation	Recommendation for Civil Employment
S1H1A1P2 (P2)E1	Pemphigus vulgaris,				

40. Details of Representations in Sports (National/International) :-

Ser No	Event	Year	Distinction

41. Spl skills :-

(To be filled by CO/OC Depot Bn/Coy)

42. Imp appts tenated during service :-

(To be filled by CO/OC Depot Bn/Coy)

43. Joint Photograph of Pensioner with NOK



44. Joint Photograph of Pensioner with all dependents as mentioned at Para 31 above

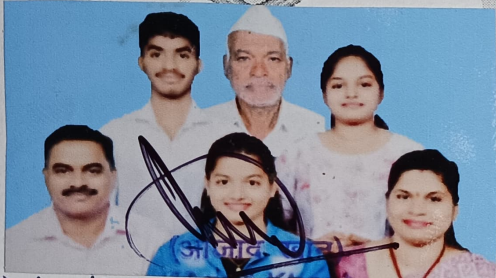

Date: 30/06/2024 Signature of Soldier [Signature]

ले० कर्नल
Lt Col
डिपो कम्पनी कमान्डर
Depot Coy Cdr
(Signature of Issuing Authority)
कृते कमान अधिकारी
For Commanding Officer

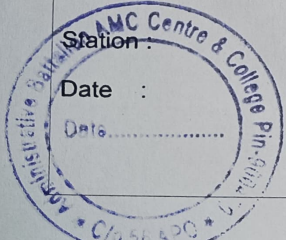

PART II

TO BE FILLED IN BY ZILA SAINIK BOARD

1. Details of Registration for Re-employment :-
 - (a) RSB / ZSB Registration Details :-
 - (i) Registration Number : _____
 - (ii) Date : _____
 - (b) Civil Exchange Registration Details :-
 - (i) Registration Number : _____
 - (ii) Date : _____
 - (iii) Registering Agency : _____
2. Ex-serviceman / Veteran Card No : _____
3. Voter ID Card No : _____
4. AWHO Allotment, if any : _____
5. Extended Insurance Certificate details :-
 - (a) Certificate No : _____
 - (b) Name of Nominee : _____
 - (c) Dt of expiry of certificate : _____
6. ZSB/RSB ID No/EXSM ID No : _____

Station :

Date :

(Signature with Seal)

**FITNESS CERTIFICATE FOR
CIVIL EMPLOYMENT**

To whomsoever it may concern:-

1. This is to certify that JC702408K Sub Parge Yuvaraj Sopan is being released from service in Low Medical Category for the following conditions:-

(a) PEMPHIGUS VULGARIS
(L10.0)

2. He is FIT for all types of employment in civil.

AUTH: RMB dated 04 Apr 2024 held at AICTS, Pune.

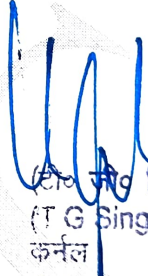

(T G Singh)

कर्नल
Col
कॉर्मांडक ब्रिगेडियर रिकार्ड्स
Otg Brig Records